

MODEL NO. : TM050RDH03ISSUED DATE: 2011-04-08VERSION : Ver 1.1

- Preliminary Specification
 Final Product Specification

Customer :

Approved by	Notes

SHANGHAI TIANMA Confirmed :

Prepared by	Checked by	Approved by

This technical specification is subjected to change without notice



Table of Contents

.....	1
Record of Revision.....	3
1. General Specifications	4
2. Input/Output Terminals	5
3. Absolute Maximum Ratings	6
4. Electrical Characteristics.....	6
4.1 Driving TFT LCD Panel.....	6
4.2 Driving Backlight.....	6
4.3 Block Diagram	7
5. Interface input timing	8
6. Optical Characteristics	12
7. Environmental / Reliability Test	15
8. Mechanical Drawing.....	16
9. Packing Drawing	17
10. Precaution for Use of LCD Modules.....	18



1. General Specifications

Feature		Spec
Display Spec.	Size	5.0 inch
	Resolution	800(RGB) x 480
	Interface	RGB 24 bits
	Color Depth	16.7M
	Technology Type	a-Si
	Pixel Pitch (mm)	0.360x0.360
	Pixel Configuration	R.G.B. Vertical Stripe
	Display Mode	TM with Normally White
	Surface Treatment(Up Polarizer)	Anti-Glare(3H)
	Viewing Direction	12 o'clock
	Gray Scale Inversion Direction	6 o'clock
	LCM (W x H x D) (mm)	120.70x75.80x3.10
Mechanical Characteristics	Active Area(mm)	108.00x64.80
	With /Without TSP	Without TSP
	Weight (g)	TBD
	LED Numbers	14 LEDs

Note 1: Viewing direction for best image quality is different from TFT definition, there is a 180 degree shift.

Note 2: Requirements on Environmental Protection: Q/S0002

Note 3: LCM weight tolerance: $\pm 5\%$



2. Input/Output Terminals

2.1 CN1 pin assignment (Signal interface)

No	Symbol	I/O	Description	Comment
1	VLED-	P	Back light cathode	
2	VLED+	P	Back light anode	
3	GND	P	Ground	
4	VDD	P	Power supply	
5	R0	I	Data input	
6	R1	I	Data input	
7	R2	I	Data input	
8	R3	I	Data input	
9	R4	I	Data input	
10	R5	I	Data input	
11	R6	I	Data input	
12	R7	I	Data input	
13	G0	I	Data input	
14	G1	I	Data input	
15	G2	I	Data input	
16	G3	I	Data input	
17	G4	I	Data input	
18	G5	I	Data input	
19	G6	I	Data input	
20	G7	I	Data input	
21	B0	I	Data input	
22	B1	I	Data input	
23	B2	I	Data input	
24	B3	I	Data input	
25	B4	I	Data input	
26	B5	I	Data input	
27	B6	I	Data input	
28	B7	I	Data input	
29	GND	P	Ground	
30	CLKIN	I	Clock for input data. Data latched at falling edge of this signal.	
31	STBYB	I	Standby mode. STBYB="1": Normally operation. STBYB="0": Standby mode .Timing controller, source driver will turn off, all output are High-Z.	
32	HSD	I	Horizontal sync input.	
33	VSD	I	Vertical sync input	
34	DEN	I	Data input enable. Active high to enable the data input bus under "DE Mode ".	
35	NC	--	No connection	
36	GND	P	Ground	
37	XR	--	NC	
38	YD	--	NC	
39	XL	--	NC	
40	YU	--	NC	

Note1: I/O definition: I----Input O----Output P----Power/Ground

The information contained herein is the exclusive property of SHANGHAI TIANMA MICRO-ELECTRONICS Corporation, and shall not be distributed, reproduced, or disclosed in whole or in part without prior written permission of SHANGHAI TIANMA MICRO-ELECTRONICS Corporation.



3 Absolute Maximum Ratings

3.1 Driving TFT LCD Panel

GND=0V, Ta=25°C

Item	Symbol	Min	Max	Unit	Remark
Supply Voltage	VDD	-0.5	5.0	V	
Back Light Forward Current	I _{LED}		25	mA	For each LED
Operating Temperature	T _{OPR}	-20	70	°C	
Storage Temperature	T _{STG}	-30	80	°C	

Note1: The parameter is for driver IC (gate driver, source driver) only.

Note2: Signals include R0~R7, G0~G7, B0~B7, CLKIN, STBYB, HSD, VSD, DEN

Table 3.1 absolute maximum rating

4 Electrical Characteristics

4.1 Driving TFT LCD Panel

GND=0V, Ta=25°C

Item	Symbol	Min	Typ	Max	Unit	Remark
Supply Voltage	VDD	3.0	3.3	3.6	V	
Input Signal Voltage	Low Level	V _{IL}	0	--	0.3xVDD	V
	High Level	V _{IH}	0.7xVDD	--	VDD	V
Output Signal Voltage	Low Level	V _{OL}	--	--	GND+0.4	V
	High Level	V _{OH}	VDD-0.4	--	--	V
(Panel+LSI) Power Consumption	Black Mode (60Hz)		TBD		mW	
	Standby Mode		TBD		mW	

Note1: For different LCM, the value may have a bit of difference.

Note2: To test the current dissipation, use "all Black Pattern".

Table 4.1 LCD module electrical characteristics

4.2 Driving Backlight

Item	Symbol	Min	Typ	Max	Unit	Remark
Channel1	I _F	-	20	-	mA	Note 1
Forward Voltage	V _F	-	21.7	-	V	
Backlight Power Consumption	W _{BL}	-	868	-	mW	
Life Time	-	10,000	(20,000)		Hrs	Note 3

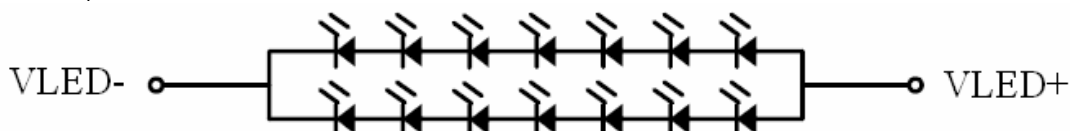
Note 1: I_F is defined for one channel LED. There are total two LED channels in back light unit

Note 2: Optical performance should be evaluated at Ta=25°C only.



Note 3: If LED is driven by high current, high ambient temperature & humidity condition. The life time of LED will be reduced. Operating life means brightness goes down to 50% initial brightness. Typical operating life time is estimated data.

Table 4.2 LED backlight characteristics

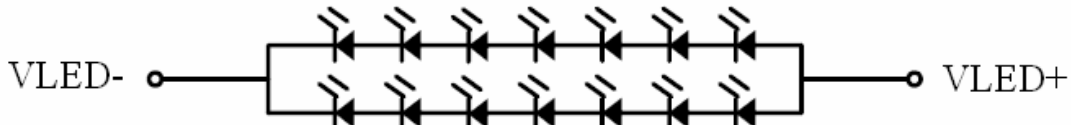
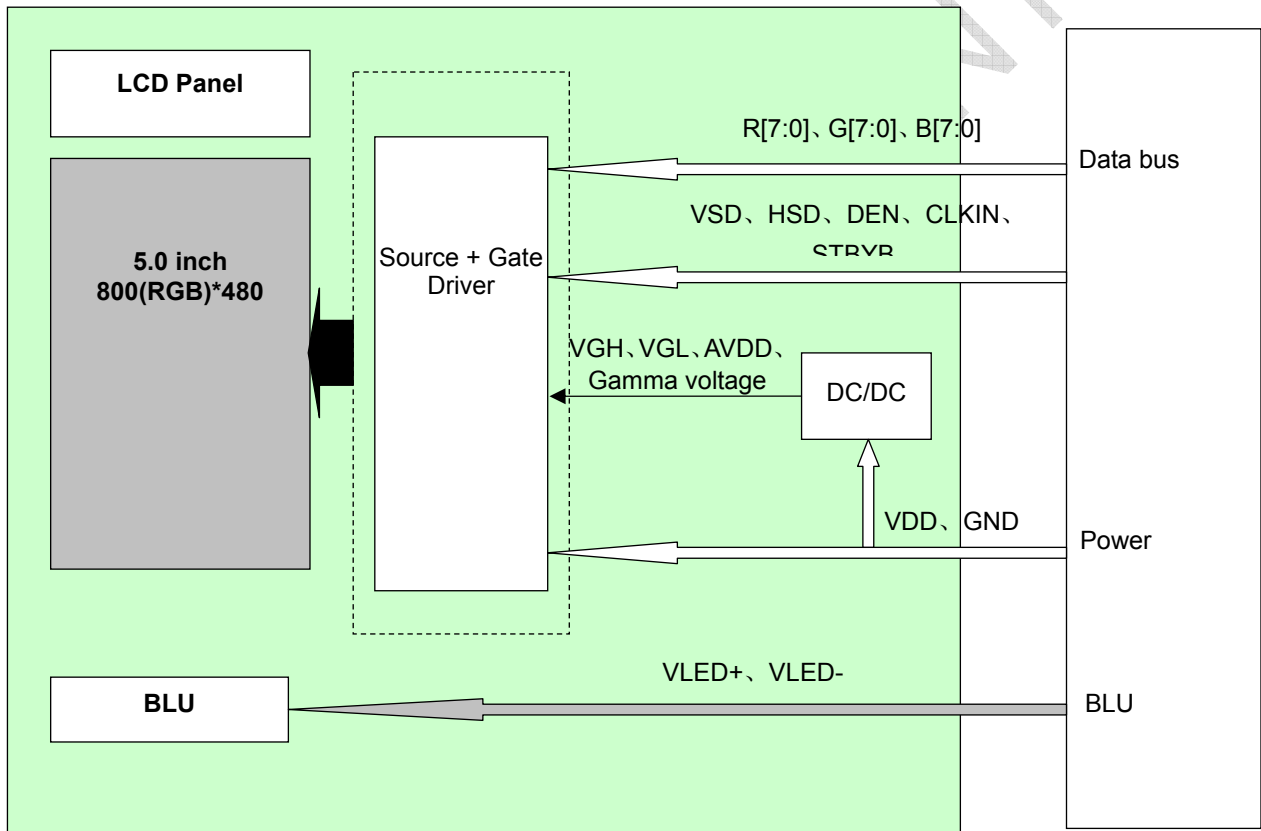

Figure 4.2 LED connection of backlight

4.3 Block Diagram





5. Interface timing

5.1 Input Clock and Data Timing

Parameter	Symbol	Min	Typ	Max	Unit	Remark
HSD Setup Time	T_{hst}	8			ns	
HSD Hold Time	T_{hhd}	8	-	-	ns	
VSD Setup Time	T_{vst}	8			ns	
VSD Hold Time	T_{vhd}	8	-	-	ns	
Data Setup Time	T_{dsu}	8			ns	
Data Hold Time	T_{dhd}	8	-	-	ns	
DE Setup Time	T_{esu}	8			ns	
DE Hold Time	T_{ehd}	8	-	-	ns	
CLKIN Cycle Time	T_{cph}	20			ns	
CLKIN Pulse Width	T_{cwh}	40	50	60	%	
Output stable time	T_{sst}	-	-	6	us	
VDD Power ON Slew rate	T_{por}			20	ms	
RSTB pulse width	TR_{st}	10	-	-	us	

Table 5.1 Input Clock and Data Timing

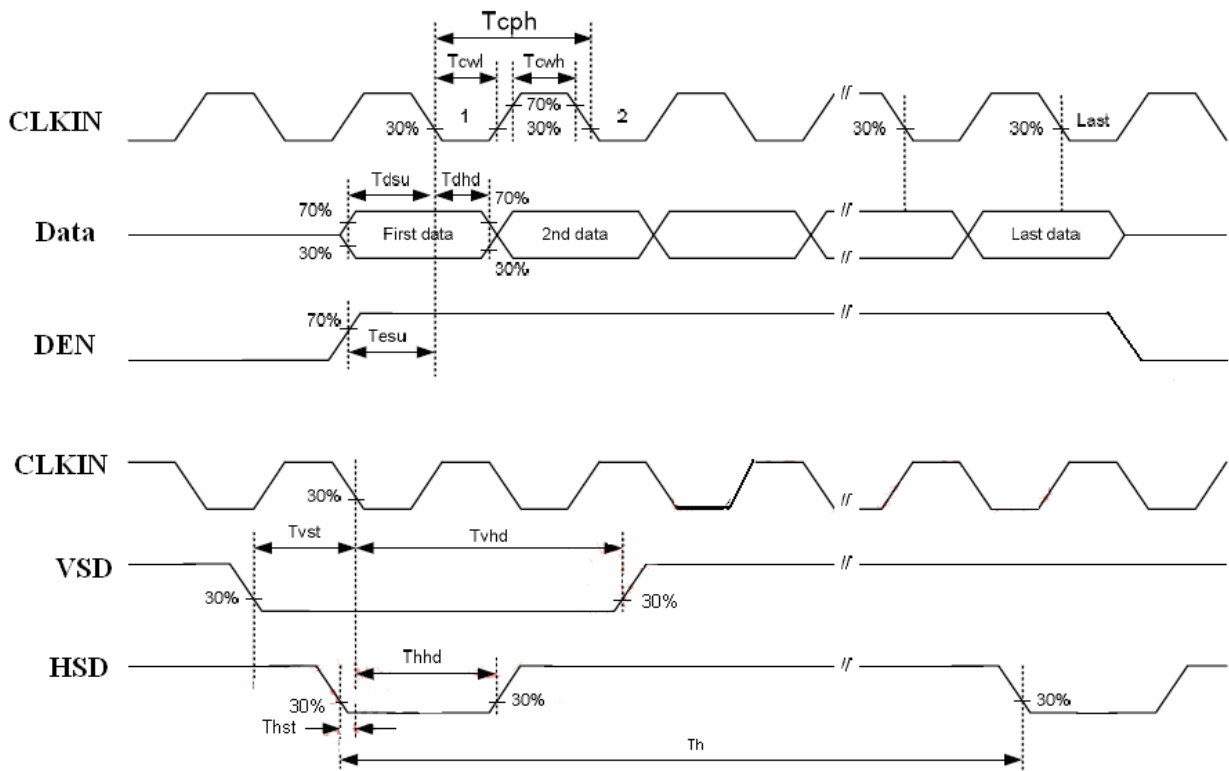

Figure 5.1 Input Clock and Data Timing Diagram



5.2 Data Input format

5.2.1 Parameter Setting Of Timing

Parameter	Symbol	Spec			Unit
		Min	Typ	Max	
Horizontal display area	t_{hd}	800			CLKIN
CLKIN frequency (60Hz)	f_{clk}	-	30	50	MHZ
One Horizontal Line	t_h	889	928	1143	CLKIN
HSD pulse width	t_{hpw}	1	48	255	CLKIN
HSD blanking	t_{hb}	88			CLKIN
HSD front porch	t_{hfp}	1	40	255	CLKIN
Vertical display area	t_{vd}	480			T_H
VSD period time	t_v	513	525	767	T_H
VSD pulse width	t_{vpw}	3	3	255	T_H
VSD Blanking(tv _b)	t_{vb}	32			T_H
VSD Front porch (tv _{fp})	t_{vfp}	1	13	255	T_H

Table 5.2 Parameter Setting Of Timing

5.2.2 Horizontal Input Timing Diagram

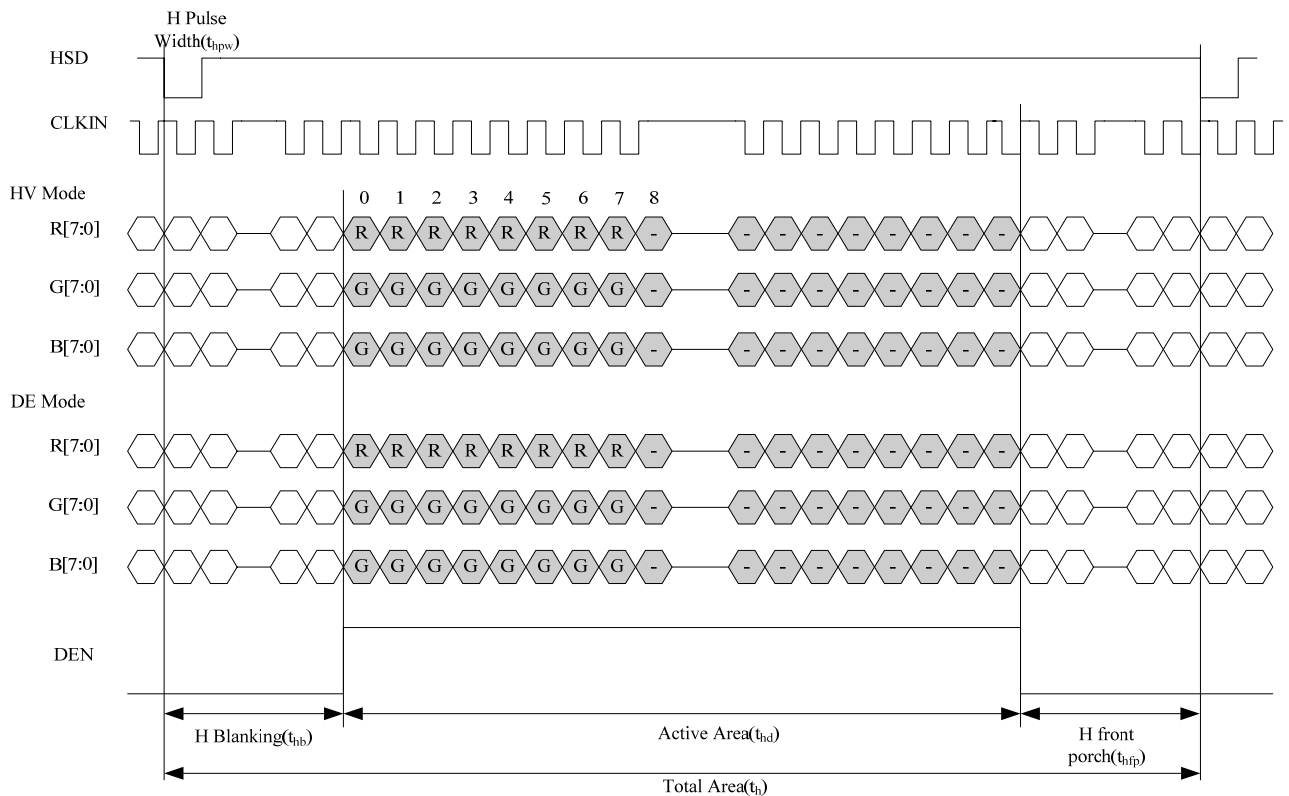

Figure 5.2 Horizontal Input Timing Diagram

The information contained herein is the exclusive property of SHANGHAI TIANMA MICRO-ELECTRONICS Corporation, and shall not be distributed, reproduced, or disclosed in whole or in part without prior written permission of SHANGHAI TIANMA MICRO-ELECTRONICS Corporation.



5.2.3 Vertical Input Timing Diagram

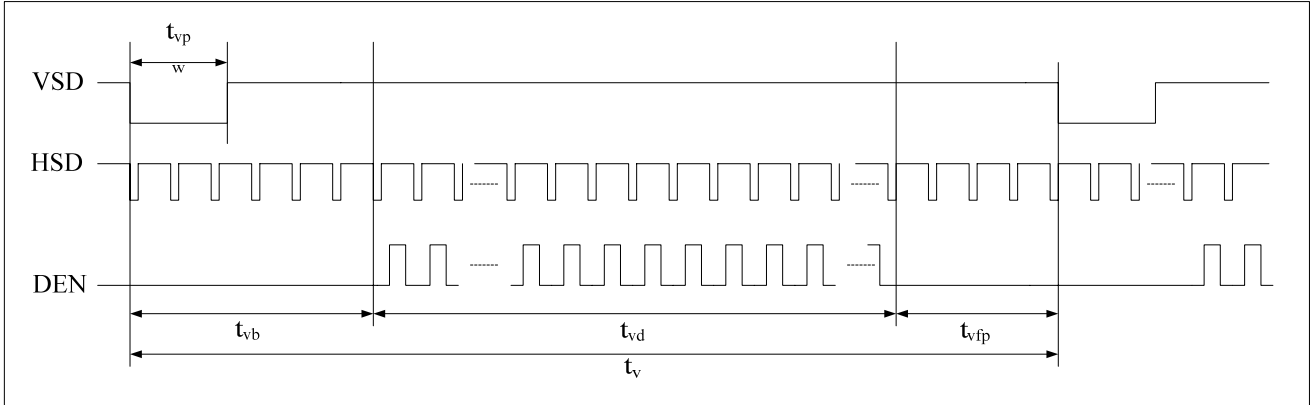

Figure 5.2.3 Vertical Input Timing Diagram

5.3 Power ON/OFF Sequence

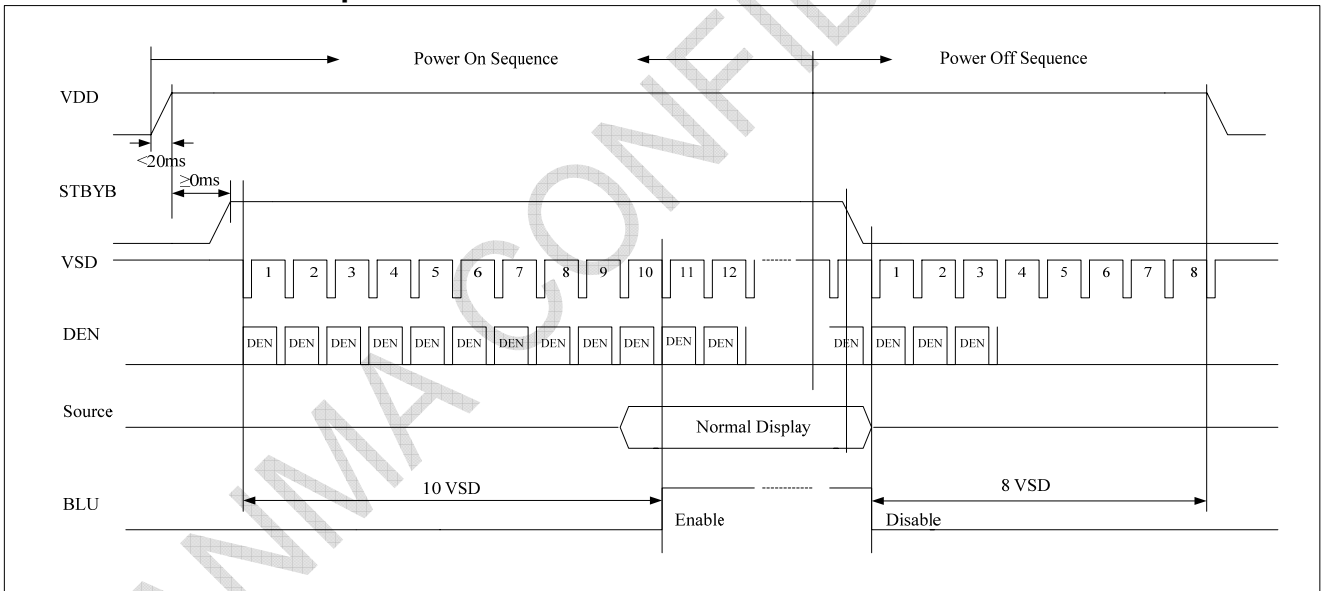

Figure 5.3 Power On/Off Sequence

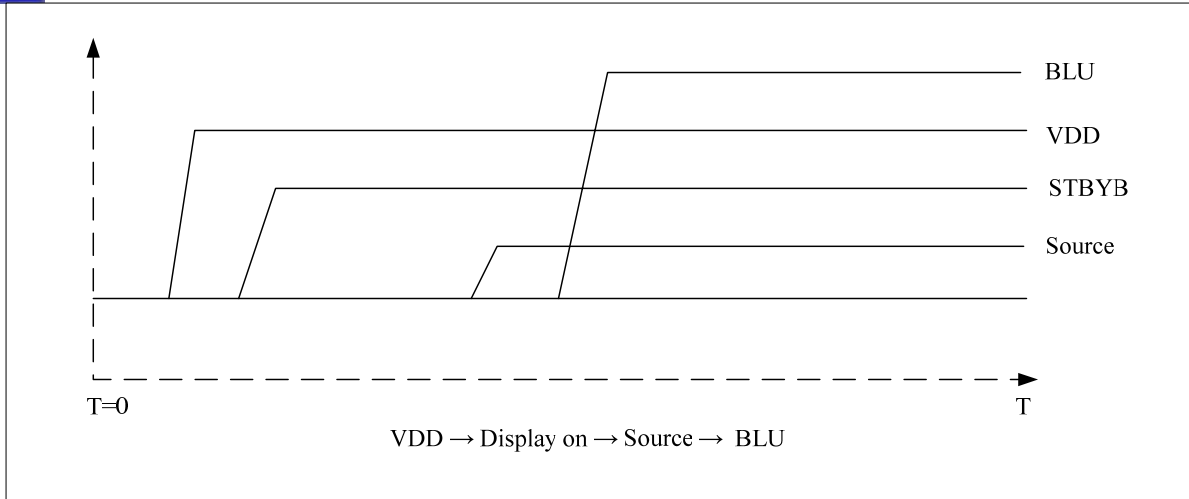

Figure 5.3 Power On Sequence

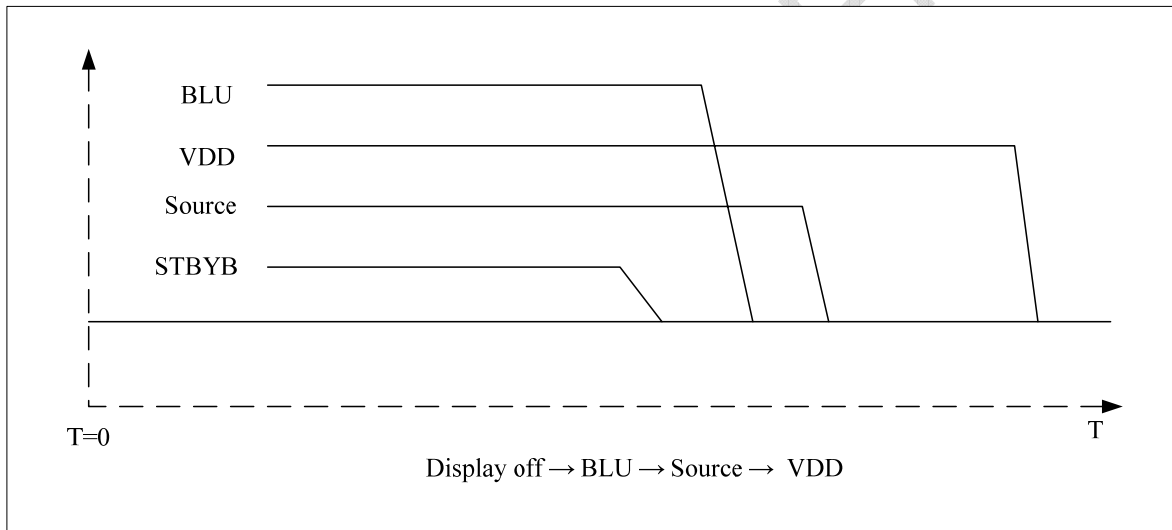

Figure 5.3 Power Off Sequence

**6. Optical Characteristics**

Item	Symbol	Condition	Min	Typ	Max	Unit	Remark
View Angles	θT	$CR \geq 10$	40	50	--	Degree	Note 2
	θB		60	70	--		
	θL		60	70	--		
	θR		60	70	--		
Contrast Ratio	CR	$\theta=0^\circ$	500	600	--		Note1、Note3
Response Time	T_{ON}	25°C	--	20	30	ms	Note1 Note4
	T_{OFF}						
Chromaticity	White	Backlight is on	x	0.260	0.310	0.360	Note5 Note1
			y	0.280	0.330	0.380	
	Red		x	0.540	0.590	0.640	
			y	0.300	0.350	0.400	
	Green		x	0.298	0.348	0.398	
			y	0.520	0.570	0.620	
	Blue		x	0.095	0.145	0.195	
			y	0.060	0.110	0.160	
Uniformity	U		75	80	--	%	Note1、Note6
NTSC			--	50	--	%	Note 5
Luminance	L		200	250	--	cd/m ²	Note1、Note7

Test Conditions:

1. $I_F = 20\text{mA}$ (one channel), $V_F = 23.1\text{V}$, the ambient temperature is 25°C.
2. The test systems refer to Note 1 and Note 2.



Note 1: Definition of optical measurement system.

The optical characteristics should be measured in dark room. After 5 Minutes operation, the optical properties are measured at the center point of the LCD screen. All input terminals LCD panel must be ground when measuring the center area of the panel.

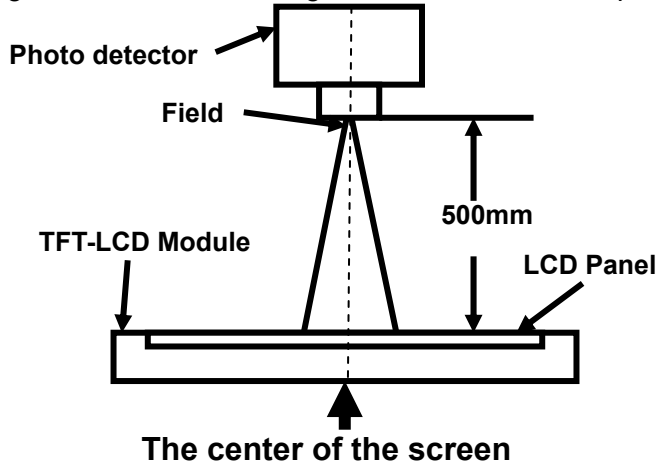

Item	Photo detector	Field
Contrast Ratio	SR-3A	1°
Luminance		
Chromaticity		
Lum Uniformity		
Response Time	BM-7A	2°

Note 2: Definition of viewing angle range and measurement system.

viewing angle is measured at the center point of the LCD by CONOSCOPE(ergo-80).

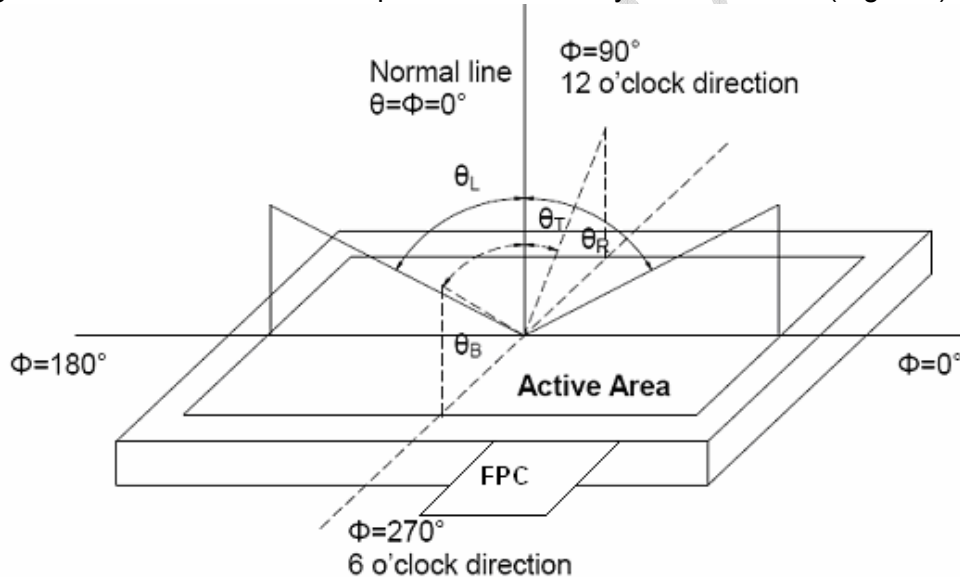

Note 3: Definition of contrast ratio

$$\text{Contrast ratio (CR)} = \frac{\text{Luminance measured when LCD is on the "White" state}}{\text{Luminance measured when LCD is on the "Black" state}}$$

“White state “: The state is that the LCD should drive by V_{white}.

“Black state”: The state is that the LCD should drive by V_{black}.

V_{white}: To be determined V_{black}: To be determined.

Note 4: Definition of Response time

The response time is defined as the LCD optical switching time interval between “White” state and “Black” state. Rise time (T_{ON}) is the time between photo detector output intensity changed from 90% to 10%. And fall time (T_{OFF}) is the time between photo detector output intensity changed from 10% to 90%.

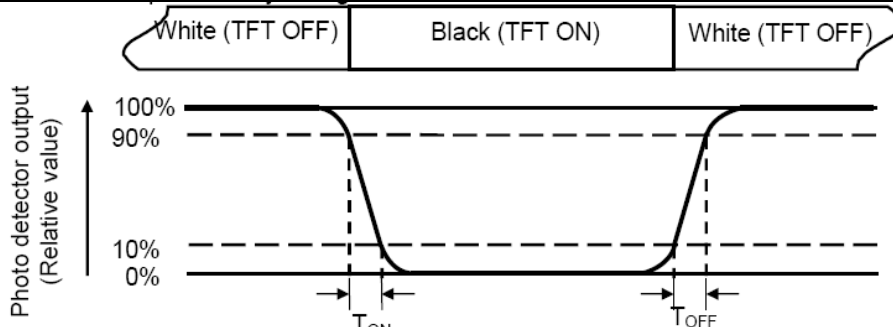

Note 5: Definition of color chromaticity (CIE1931)
 Color coordinates measured at center point of LCD.

Note 6: Definition of Luminance Uniformity

Active area is divided into 9 measuring areas (Refer Fig. 2). Every measuring point is placed at the center of each measuring area.

$$\text{Luminance Uniformity (U)} = \text{Lmin} / \text{Lmax}$$

L-----Active area length W----- Active area width

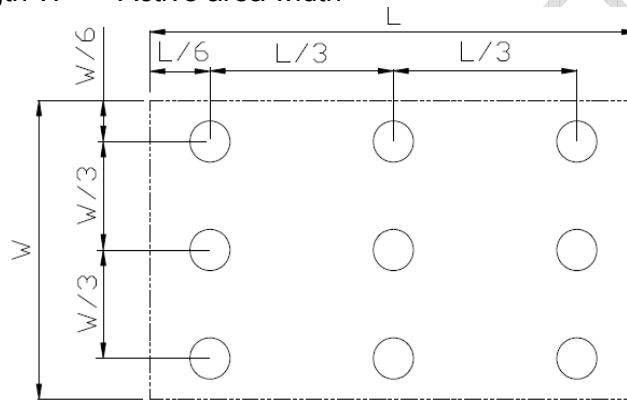

Lmax: The measured Maximum luminance of all measurement position.

Lmin: The measured Minimum luminance of all measurement position.

Note 7: Definition of Luminance:

Measure the luminance of white state at center point.

**7. Environmental / Reliability Test**

No	Test Item	Condition	Remarks
1	High Temperature Operation	Ts = +70°C, 240 hours	Note1 IEC60068-2-1,GB2423.2
2	Low Temperature Operation	Ta = -20°C, 240 hours	IEC60068-2-1 GB2423.1
3	High Temperature Storage	Ta = +80°C, 240 hours	IEC60068-2-1 GB2423.2
4	Low Temperature Storage	Ta = -30°C, 240 hours	IEC60068-2-1 GB2423.1
5	Storage at High Temperature and Humidity	Ta = +60°C, 90% RH max,240hours	Note2 IEC60068-2-78 GB/T2423.3
6	Thermal Shock (non-operation)	-20°C 30 min~+60°C 30 min, Change time:5min, 100 Cycle	Start with cold temperature, End with high temperature, IEC60068-2-14,GB2423.22
7	ESD	C=150pF,R=330Ω,5point/panel Air:±8Kv,5times; Contact:±4Kv,5times (Environment:15°C~35°C, 30%~60%.86Kpa~106Kpa)	IEC61000-4-2 GB/T17626.2
8	Vibration Test	Frequency range:10~200Hz Stroke:1.5mm Sweep:10Hz~200Hz~10Hz 30 minutes for each direction of X.Y.Z. (1.5 hours for total)	IEC60068-2-6 GB/T2423.10
9	Mechanical Shock (Non Op)	Half Sine Wave 60G 20ms, ±X,±Y,±Z 3times for each direction	IEC60068-2-27 GB/T2423.5
10	Package Drop Test	Height:60cm, 1corner,3edges,6surfaces	IEC60068-2-32 GB/T2423.8
11	Package Vibration Test	Random Vibration: 0.015G*G/Hz for 5-200Hz, -6dB/Octave from 200-500Hz 2 hours for each direction of X,Y,Z (6 hours for total)	IEC60068-2-34 GB/T2423.11

Note1: Ts is the temperature of panel's surface.

Note2: Ta is the ambient temperature of samples.



8. Mechanical Drawing

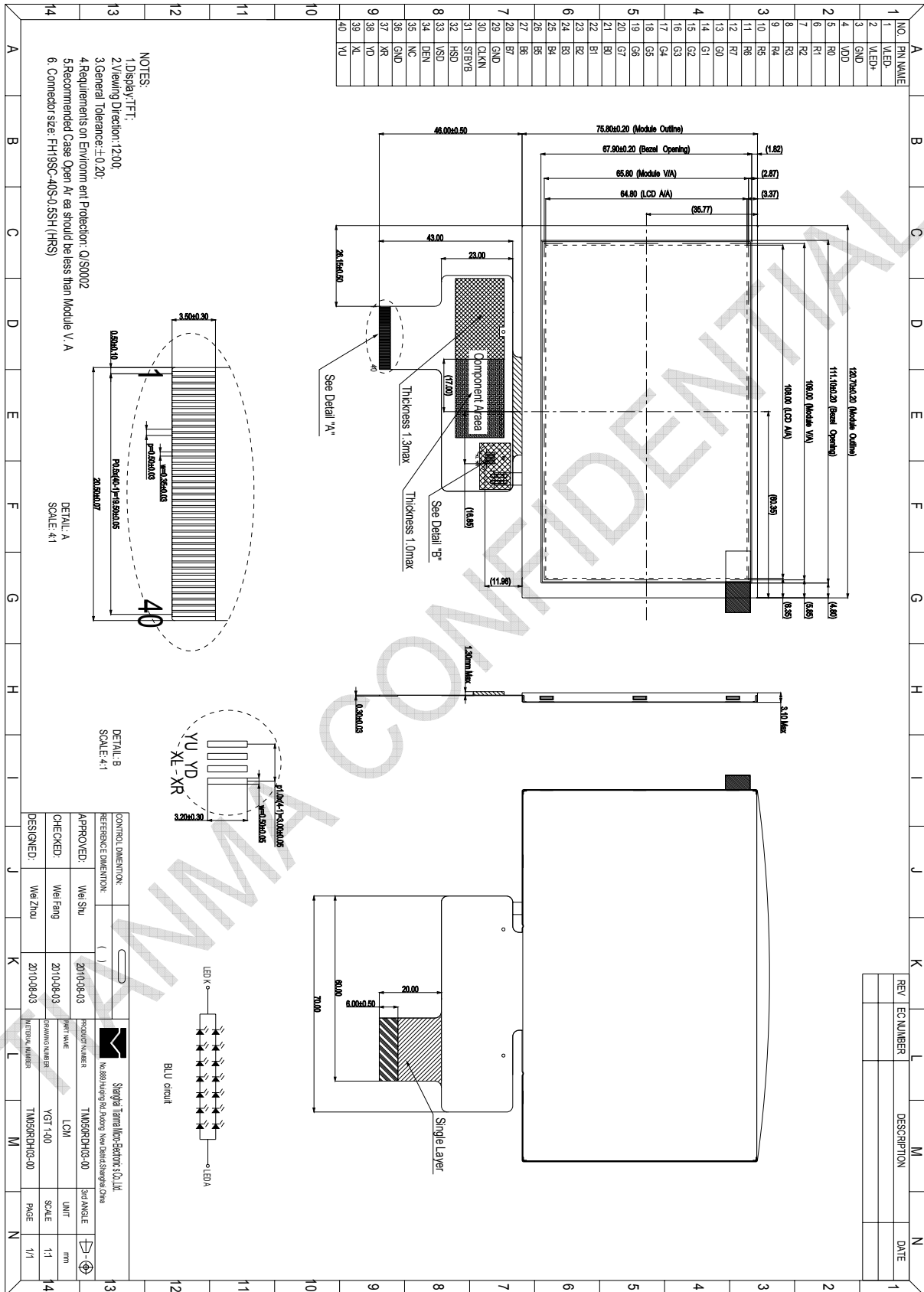

The information contained herein is the exclusive property of SHANGHAI TIANMA MICRO-ELECTRONICS Corporation, and shall not be distributed, reproduced, or disclosed in whole or in part without prior written permission of SHANGHAI TIANMA MICRO-ELECTRONICS Corporation.



9. Packing Drawing

9.1 Packaging Material

No	Item	Model(Material)	Dimensions (mm)	Unit Weigt (Kg)	Quantity	Remark
1	LCM module	TM050RDH03-00	120.7x75.8x3.1	TBD	112	
2	Partition_1	Corrugated paper	513X333X106	0.7	2	
3	Anti-static Bag	PE	136X140X0.05	0.0007	112	Anti-static
4	Dust-Proof Bag	PE	-	0.06	1	
5	Partition_2	Corrugated Paper	505X332X4.0	0.09	3	
6	Corrugated Bar	Corrugated paper	513X110x31	0.048	4	
7	Beauty-grain	Beauty-grain	30x10	--	112	
8	Desiccant	Desiccant	45x35	0.002	24	
9	Carton	Corrugated paper	530X350X250	1.10	1	
10	Total weight			TBD		

Note: Packaging Specification and Quantity

Module quantity in a carton: 28pcs(per row)x2(per column)x2= 112pcs

9.2 Packing Instruction

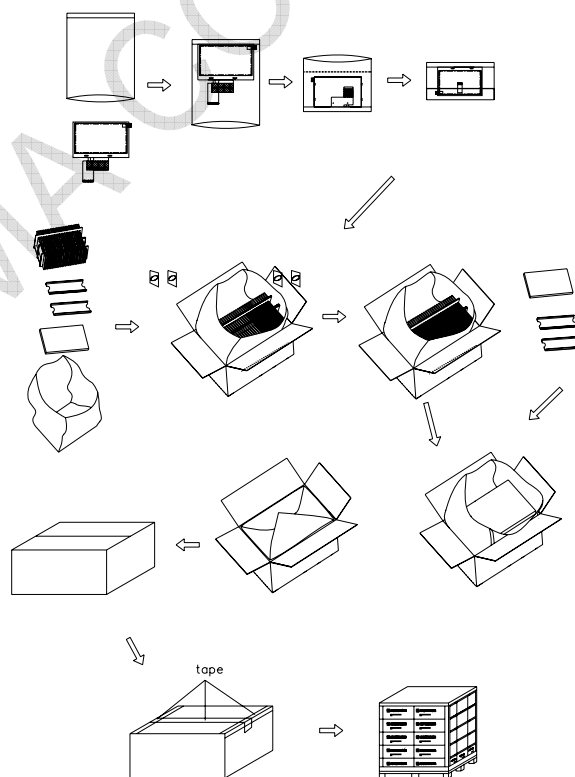

The information contained herein is the exclusive property of SHANGHAI TIANMA MICRO-ELECTRONICS Corporation, and shall not be distributed, reproduced, or disclosed in whole or in part without prior written permission of SHANGHAI TIANMA MICRO-ELECTRONICS Corporation.



10. Precautions for Use of LCD Modules

10.1 Handling Precautions

10.1.1 The display panel is made of glass. Do not subject it to a mechanical shock by dropping it from a high place, etc.

10.1.2 If the display panel is damaged and the liquid crystal substance inside it leaks out, be sure not to get any in your mouth, if the substance comes into contact with your skin or clothes, promptly wash it off using soap and water.

10.1.3 Do not apply excessive force to the display surface or the adjoining areas since this may cause the color tone to vary.

10.1.4 The polarizer covering the display surface of the LCD module is soft and easily scratched. Handle this polarizer carefully.

10.1.5 If the display surface is contaminated, breathe on the surface and gently wipe it with a soft dry cloth. If still not completely clear, moisten cloth with one of the following solvents:

- Isopropyl alcohol
- Ethyl alcohol

Solvents other than those mentioned above may damage the polarizer. Especially, do not use the following:

- Water
- Ketone
- Aromatic solvents

10.1.6 Do not attempt to disassemble the LCD Module.

10.1.7 If the logic circuit power is off, do not apply the input signals.

10.1.8 To prevent destruction of the elements by static electricity, be careful to maintain an optimum work environment.

10.1.8.1 Be sure to ground the body when handling the LCD Modules.

10.1.8.2 Tools required for assembly, such as soldering irons, must be properly ground.

10.1.8.3 To reduce the amount of static electricity generated, do not conduct assembly and other work under dry conditions.

10.1.8.4 The LCD Module is coated with a film to protect the display surface. Be care when peeling off this protective film since static electricity may be generated.

10.2 Storage precautions

10.2.1 When storing the LCD modules, avoid exposure to direct sunlight or to the light of fluorescent lamps.

10.2.2 The LCD modules should be stored under the storage temperature range. If the LCD modules will be stored for a long time, the recommend condition is:

Temperature : 0°C ~ 40°C Relatively humidity: ≤80%

10.2.3 The LCD modules should be stored in the room without acid, alkali and harmful gas.

10.3 Transportation Precautions

10.3.1 The LCD modules should be no falling and violent shocking during transportation, and also should avoid excessive press, water, damp and sunshine.